

HS-109 Series Vibration Sensor

Triaxial, M12 Connector, 100mV/g Industrial Accelerometer



Typical Applications

- Proven use in vibration monitoring for offline applications using commercially available data collectors and online monitoring systems in the fields of Building Services, Civil Engineering, Paper and Pulp, Mining, Metals Manufacture, Utilities, Automotive, Water and Waste Treatment, Pharmaceutical, Aerospace, etc.
- **Protecting...**
Fans, Motors, Pumps, Compressors, Centrifuges, Conveyers, Air Handlers, Gearboxes, Rolls, Dryers, Presses, Cooling, HVAC, Spindles, Machine Tooling, Process Equipment and many more.

Technical Performance

Mounted Base Resonance	17 kHz (nominal)
Sensitivity	100 mV/g $\pm 10\%$ Nominal 80 Hz at 22 °C per axes
Frequency Response	6 Hz to 6 kHz $\pm 5\%$ 0.8 Hz to 10 kHz ± 3 dB
Isolation	Base isolated
Measurement Range	± 80 g
Transverse Sensitivity	Less than 5%

Electrical

Electrical Noise	0.1 mg max
Current Range	0.5 mA to 8 mA
Bias Voltage	10 - 12 Volts DC
Settling Time	2 seconds
Output Impedance	200 Ohms max.
Case Isolation	$>10^8$ Ohms at 500 Volts

Environmental

Operating Temperature Range	-55 to 140 °C (See How To Order)
Sealing	IP67
Maximum Shock	5000 g
Emissions	EN61000-6-4:2007
Immunity	EN61000-6-2:2005

Mechanical

Case Material	Stainless Steel
Sensing Element/Construction	PZT/Compression
Mounting Torque	8 Nm
Weight	530 grams
Mounting Threads	See 'How to order' table
Options	Integral cable, filters, temperature output, various connector assemblies, other sensitivities

HS-109 Series Vibration Sensor

Dimensions

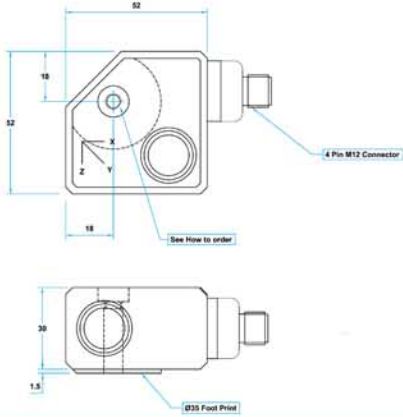

Pin 1 - X-Axis Signal (+18-30V)
 Pin 2 - Y-Axis Signal (+18-30V)
 Pin 3 - Z-Axis Signal (+18-30V)
 Pin 4 - Common (0V)

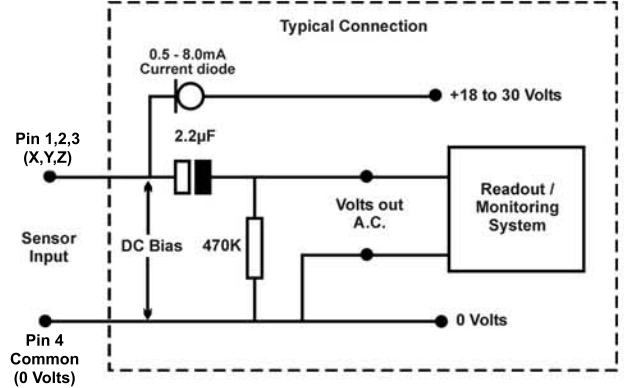
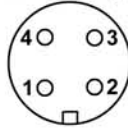

Frequency Response

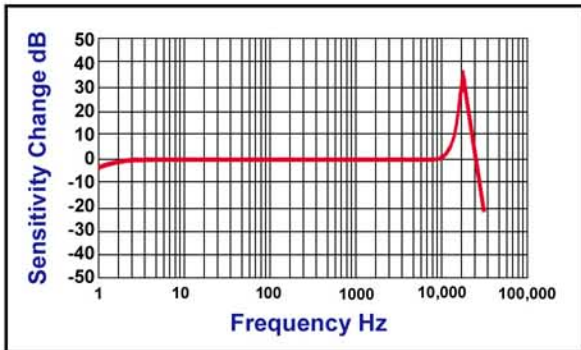

Mounting of sensor to achieve good repeatable readings.
 Vibration sensor should be firmly fixed to a flat surface (spot face surface may be needed to be produced and cable anchored to sensor body.)

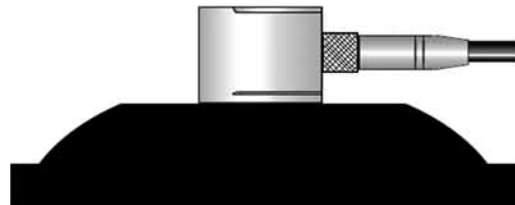

How to order

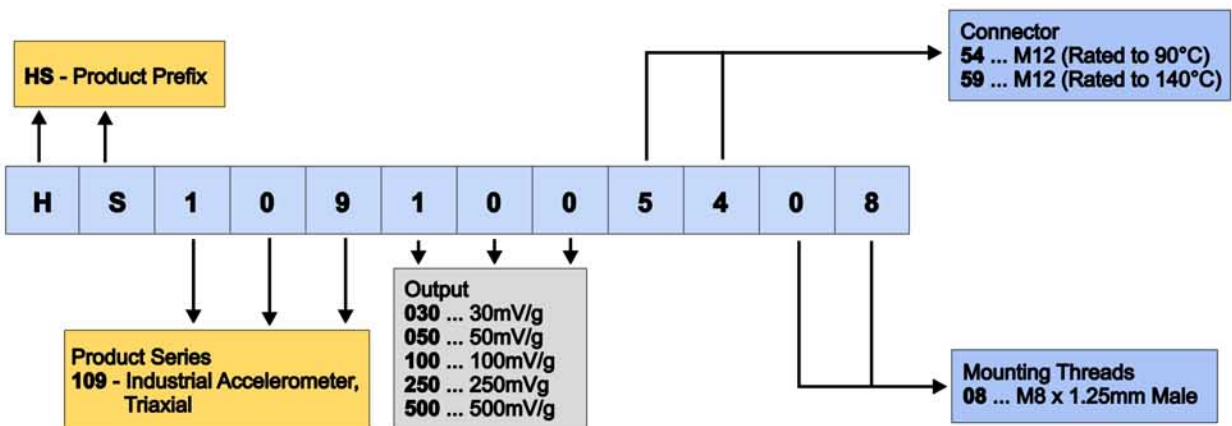

Please contact our Sales Office for information on sensor accessories (mounting studs, etc) and multichannel switch boxes.